

DUPLEX D-TYPE STRAINER

10" – 20" NB

D-TYPE DUAL BASKET STRAINER 10" – 20" (250 MM – 500 MM)

The Plenty D-Type, Duplex Basket Filters are designed with two filtration chambers for applications that require a continuous flow whilst the filter is cleaned. The D-Type employs a rugged and positive method to changeover from the operating to the standby chamber using two disc valves operated by screwed shafts. The shafts are interconnected giving a simultaneous action ensuring that a filtration chamber is always in operation. An external indicator is fitted to the shaft to show which chamber is in operation, allowing the basket in the other chamber to be removed and cleaned. The shafts are sleeved and protected from the process liquid.

The D-Type is available in five sizes from 10" to 20" (250 mm to 500 mm) NB and made from Cast Iron or

STANDARD FEATURES

- Quick release covers eliminate the need for tools for maintenance
- Hand operated
- Pressure equalising valve
- No tools required for service
- Basket cleaning without interrupting the flow
- Differential pressure connections



Cast Steel capable of operating at pressures up to 300 psig and temperatures of 200°C. They are fitted with a Stainless Steel 2mm perforated basket as standard, which can incorporate a removable mesh insert for fine filtration down to 300 mesh (50 micron). A pressure equalizing valve is fitted as standard and options include electrical changeover operation, differential pressure indication or control switch and replaceable mesh inserts from 20 to 300 mesh.

OPTIONS

- Mesh inserts, from 20 – 300 mesh, for fine filtration applications
- Alternative basket materials available
- External paint finish options
- Internal protective coatings
- Differential pressure indication / switches
- Flanged vent and drains
- Magnetic element assemblies
- Reinforced support baskets to withstand high differential pressures
- Automatic valve changeover operation

DESIGN DATA

CAST IRON BS 1452 GR 260			CAST STEEL ASTM A216 WCB		
FLANGE RATING	DESIGN PRESSURE	WORKING TEMP	FLANGE RATING	DESIGN PRESSURE	WORKING TEMP
ANSI 125FF	10.3 BARG (150 PSIG) @ 38°C	0°C - 120°C	ANSI 150/300RF	24.0 BARG (300 PSIG) @ 38°C	0°C - 200°C

Flanges drilled to Customer requirements

- All Baskets and Mesh Inserts Stainless Steel AISI 316
- Stainless Steel and Bronze (BS1400 LG2) Internals

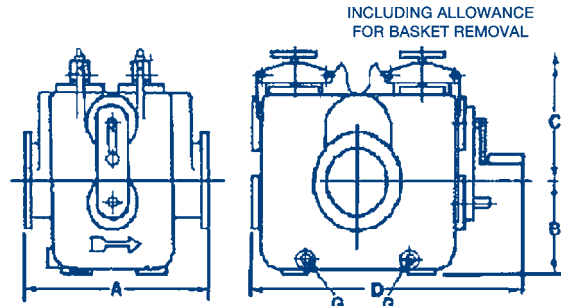

Changeover gear on right hand side looking on inlet as standard.
Available on left hand side as optional alternative at extra cost.

DIMENSIONS

Size		Model No.	No. of Baskets	A mm	B mm	C mm	D mm	G BSPT	Basket Area cm ²	Weight	
in	mm									lb	kg
10	250	10-DA	4	1025	356	1118	1505	1 1/2"	7482	2987	1356
12	300	12-DA	4	1029	381	1118	1505	1 1/2"	7482	3078	1397
16	400	16-DA	4	1260	559	1676	1734	1 1/2"	12900	5260	2388
18	450	18-DA	4	1270	584	1651	1734	1 1/2"	12900	5380	2422
20	500	20-DA	4	1270	610	1651	1734	1 1/2"	12900	5415	2458

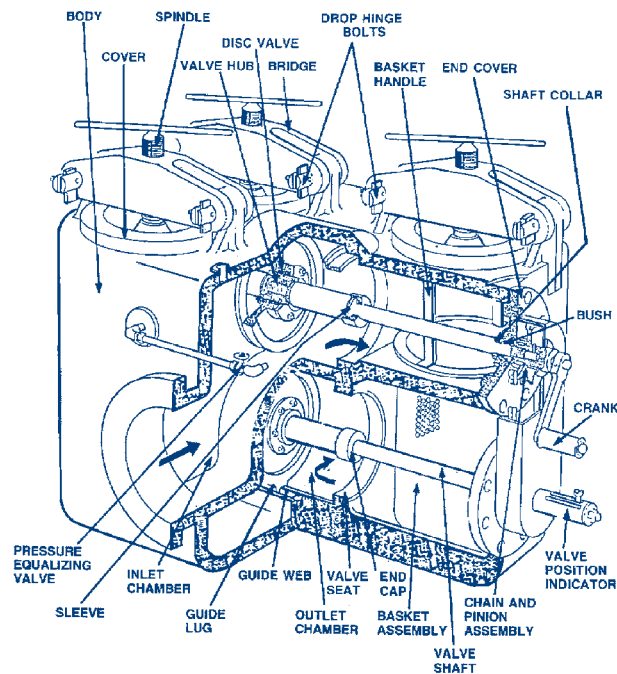

P: +44 1635 42363

F: +44 1635 49758

E: plentyfilters@celerosft.com

CELEROS™
FLOW TECHNOLOGY

| SPEED | EXCELLENCE | PARTNERSHIP