

DUPLEX D-TYPE STRAINER

6" – 8" NB

D-TYPE DUAL BASKET STRAINER 6" – 8" (150 MM – 200 MM)

Duplex D-Type strainers are used for pipelines operating continuously, where a single strainer cannot be used as the flow would have to be interrupted to clean the element. Twin filtration chambers each rated for 100% capacity and two disk type changeover valves operated by interconnected screwed shafts for simultaneous operation, ensure that a filtration chamber is always in operation.

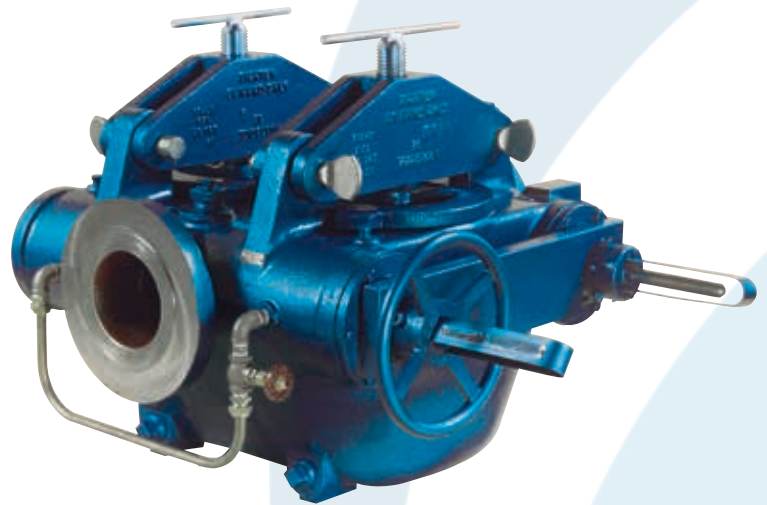

STANDARD FEATURES

- Quick release covers eliminate the need for tools for maintenance
- Resilient cover 'O' seals
- Robust basket support cages complete with replaceable mesh inserts (when required) reducing spares holding and operating costs
- Fitted with 2mm perforated stainless steel basket as standard
- External valve position indicators showing which chamber is on stream
- Replaceable valve seats
- Synchronised chain drive
- External pressure equalising valve
- Stainless steel disc valves and screwed shafts
- Single basket per chamber

OPTIONS

- Mesh inserts from 20-300 mesh available for fine filtration applications
- Alternative basket materials available
- External paint finish options
- Internal protective coatings
- Differential pressure indication / switches
- Flanged vent and drains
- Magnetic element assemblies
- Reinforced support baskets to withstand high differential pressures
- Automatic valve changeover operation

DESIGN DATA

Cast Iron BS 1452 GR 260			Cast Steel ASTM A216 WCB		
Flange Rating	Design Pressure	Working Temp	Flange Rating	Design Pressure	Working Temp
ANSI 125FF	10.3 BARG (150 PSIG) @ 38°C	0°C - 120°C	ANSI 150/300RF	24.0 BARG (350 PSIG) @ 38°C	0°C - 200°C

Flanges drilled to Customer requirements

All Baskets and Mesh Inserts Stainless Steel AISI 316

DIMENSIONS

Size		Model No.	No. of Baskets	A	B	C	D	E	F	Weight	
in	mm			mm	mm	mm	mm	mm	BSPT	lb	kg
6	150	6-DA	2	835	343	699	401	705	1½"	1003	454
8	200	8-DA	2	1016	343	788	401	705	1½"	1342	608

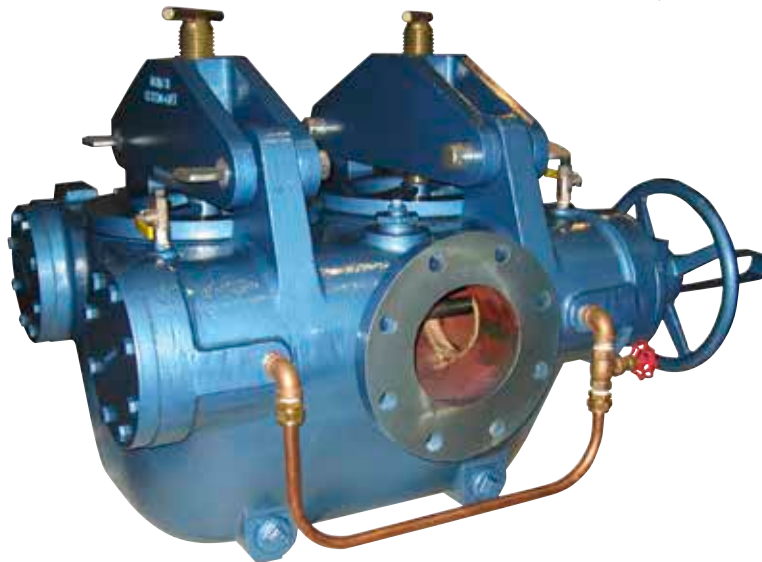
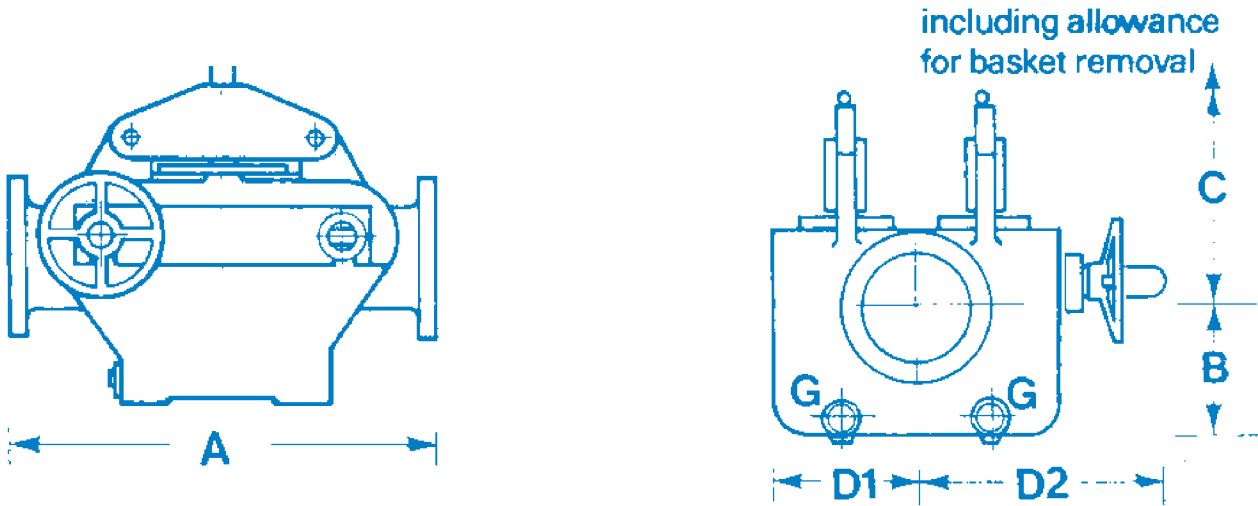

P: +44 1635 42363

F: +44 1635 49758

E: plentyfilters@celerosft.com

CELEROS™
FLOW TECHNOLOGY

| SPEED | EXCELLENCE | PARTNERSHIP

For more information about our worldwide locations, approvals, certifications, and local representatives, please visit www.celerosft.com. Celeros Flow Technology reserves the right to incorporate our latest design and material changes without notice or obligation. Design features, materials of construction and dimensions data as described in this publication are provided for informational purposes only and should not be relied upon unless confirmed in writing.
Hidrafilter, S.L. Parque Ind. Europolis, C/ Párraga, 12, 29.332 Las Rozas (Madrid) Tel: 91 636 0097 Fax 91 636 1894 e-mail hidrafilter@hidrafilter.com