



aerospace  
 climate control  
 electromechanical  
**filtration**  
 fluid & gas handling  
 hydraulics  
 pneumatics  
 process control  
 sealing & shielding



**WiFi** NOW WIFI ENABLED!



# WiFi icount Oil Sampler (IOS)

Portable condition monitoring for hydraulic oil systems. Now with WiFi.



ENGINEERING YOUR SUCCESS.

# Accurate fluid testing. Exactly where and when you need it.

## Portable, easy-to-use oil sampler. Now with on-board WiFi.

The Parker icountOS (IOS) is an innovative, solution to the challenge of measuring the quality of hydraulic oils in many different applications.

Fully WiFi enabled, the IOS delivers highly accurate, instant data, operating effectively in virtually every type of industrial environment; from renewable energy, marine and offshore, to manufacturing, mobile, agriculture, military and aerospace.

Feature-rich but highly cost effective, the IOS offers a wealth of advanced features, within a portable and easy-to-use design, at a lower cost than competing systems, and which fits within most maintenance budgets.

- Compact, lightweight and robust - the portable IOS makes field analysis quick and easy.
- Maximum versatility and adaptability - Direct sampling from a hydraulic reservoir, barrel, vehicle fuel tank; and tram high pressure online hydraulic systems (with the addition of a pressure reducing adaptor).
- Completely self-contained - laser detection particle counter, battery, pump, plus memory with web page generator for data download onto any PC or laptop, combined into a single unit.
- Proven laser detection technology from Parker - precise, repeatable, reproducible results, real time detection of both particulates, down to 4 microns (c) and dissolved water.

## Now with WiFi on-board

Featuring built in WiFi connectivity, the IOS enables remote access for real-time data - saving time, improving efficiency and increasing the effectiveness of fluid analysis

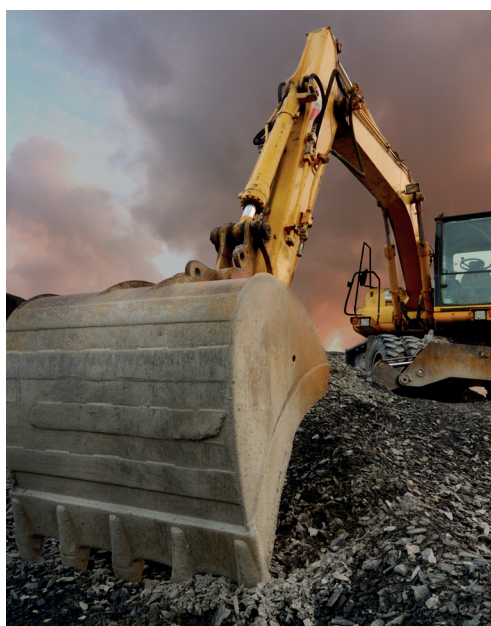
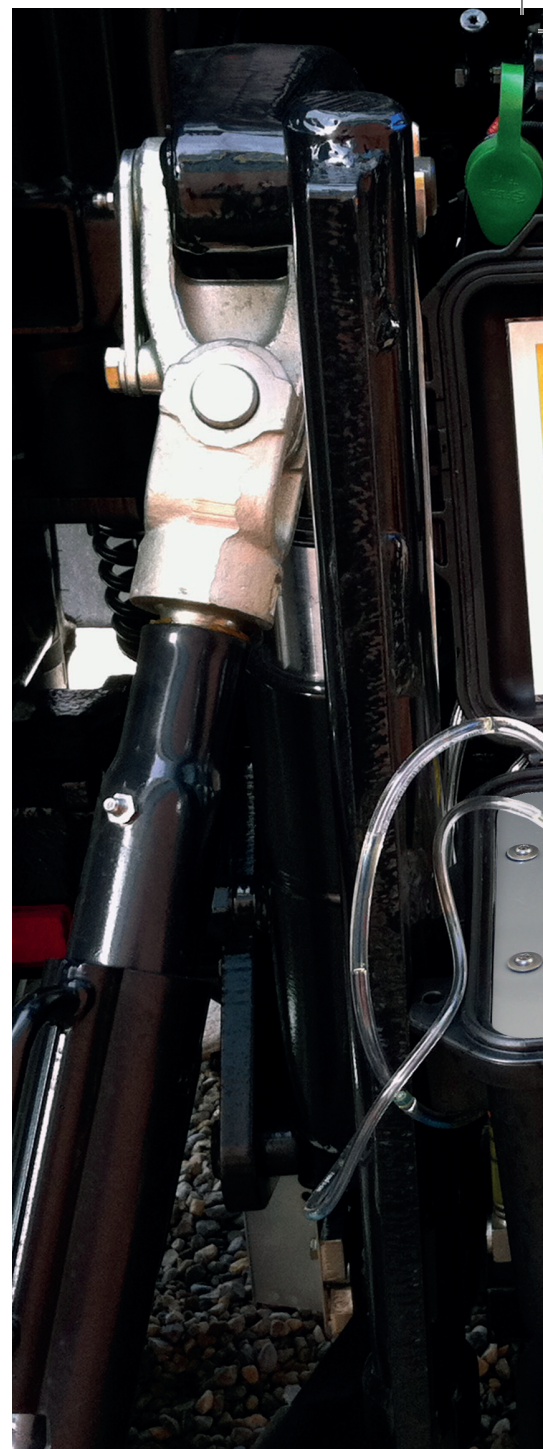



## Added control. Extra productivity.

Efficient, effective equipment maintenance is vital for maximising production up-time and reducing overall operating cost. IOS offers accurate monitoring of oil and fluid quality, providing you with the information you need to prevent expensive system failure, reduced efficiency and unscheduled repair or replacement.

User-individual wireless connection, via an embedded router, provides an instant WiFi hotspot. You can operate the IOS from remote locations, and transfer data straight to other devices, including laptops, smartphones and tablets. It means you can access and share real-time data and analysis instantly – saving you valuable time, reducing the risk of potentially damaging contamination, giving you maximum control all round.

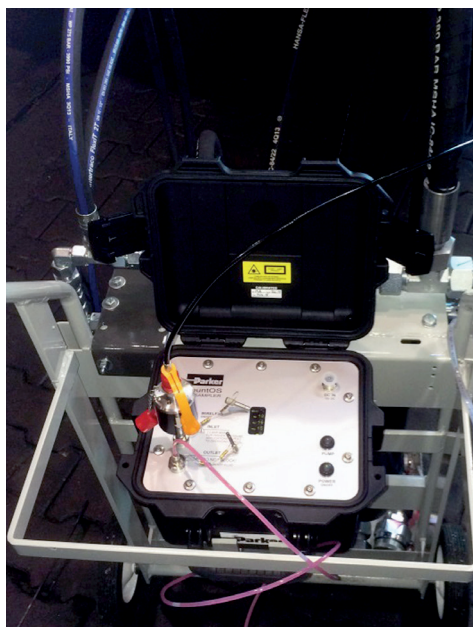
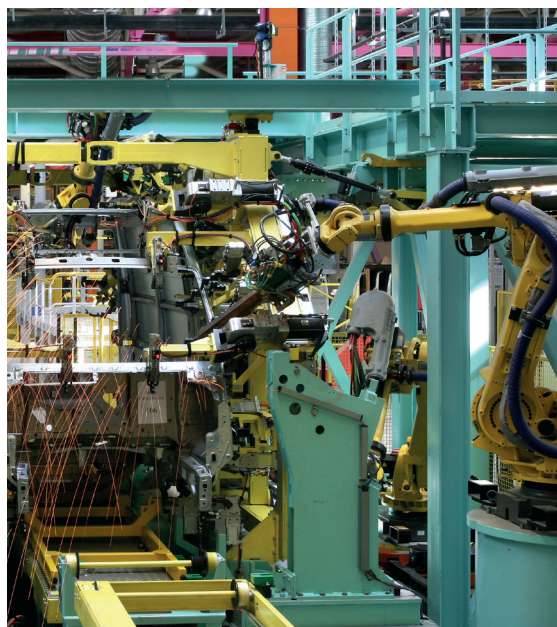

## Total System Health Management. All in one package.

In today's challenging economic landscape, maximising asset life is paramount to achieving streamlined, cost efficient operations and protecting precious resources. IOS is an integral part of Parker's Total System Health Management approach which offers an integrated and effective process of prevention, diagnostics and therapeutics.

# Improved productivity for industrial applications

IOS WiFi is designed to provide maximum usability for equipment manufacturers, plant managers, maintenance and service engineers and environmental professionals. In a broad range of on- and off-highway applications, regular system checks with the IOS are shown to boost productivity, by ensuring optimal running conditions and improving safety.

With its robust carrying case, sealed to IP67 and proven laser and diagnostics technologies, the IOS is the perfect tool for maintenance and plant engineers to use with all fixed and mobile plant and machinery.



## Construction /Off Highway

In the construction and mining sector, the IOS is ideally suited to service and fluid monitoring of essential equipment and services.

**“The IOS has proven to be an accurate and reliable service tool. I look forward to testing the WiFi capability.”**

Maintenance Engineer  
Construction Company



## Military

In the defence industry, the IOS provides essential condition monitoring support for mission critical front line battle tanks and military vehicles.

---

**“In combat situations, equipment failure is not an option. IOS helps ensure that fluid condition is always optimal”**

Procurement  
Military Customer

---



## Automotive

The IOS is the primary diagnostic instrument to help automotive manufacturers develop predictive monitoring programmes.

---

**“Cost and quality drive our business. IOS provides us with the accurate, reliable data we need for efficient operation”**

Maintenance Manager  
Automotive Manufacturer

---



# Advanced technology, for enhanced performance.



## IOS WiFi Capability

The IOS uses WiFi capability as a smart solution for effective remote control and data log transfer from the IOS to a laptop, mobile phone or tablet.

At 150 Mbps, the Nano router creates an instant WiFi hotspot and is designed to provide excellent wireless performance, allowing the remote data transfer to become an IOS reality. The WiFi hotspot range is approximately 20 metres indoors and a greater range outdoors.

- Saves time.
- Makes field analysis simpler.
- Individual user connection.
- IOS can be set up anywhere.
- A simple and 'smart' solution to oil contamination sampling.



## Laser detection technology

The IOS uses light obscuration, light blockage technology. A light source is projected through a moving column of oil. Contaminants in the fluid interrupt the light beam, casting images on a photo diode cell, where the resulting change in light intensity produces a directly proportional change in electrical output.

## High data capacity

The on-board memory provides storage capacity for up to 250,000 sets of test results. Data is displayed instantly, stored or downloaded to a PC or laptop for analysis via a standard IP68 RJ 45 patch cord connection; a 2m cable is supplied as standard. (File types - text, CSV or XML).

## Robust 'storm' casing

Together with a fully-sealed impact-resistant stainless steel front panel, the hardwearing waterproof IP54 (when open) case provides tough, reliable protection in the most demanding of applications.

The unit weighs under 5.5kg, making it an ideal 'first use' diagnostic service tool.

## Quick connection

Connecting the IOS is fast and reliable. The fluid connectors are on the front panel, with two secure push fittings: 6mm diameter inlet and 4mm diameter outlet/ drain.

Parker can supply dedicated hoses and fittings for use with most hydraulic and hydrocarbon fluids.



## Long-life remote operation

The IOS uses a long life regulated 12 Vdc power supply, with an M12, 4 pin connector, plus a rechargeable NiMH battery unit for use on site or in remote locations.

## Fast contamination detection

The IOS provides rapid detection of contaminants, with the results being shown on the front panel mounted, high visibility OLED digital display.

This provides easy identification of fluid condition, showing measured codes, the sizes per channel in microns (c), the user definable limits and moisture sensor readings as a % of relative humidity.

## Fluid and pressure control

IOS automatically adjusts the flow rate to an optimum level of 60ml/min. Total range is between 40 and 140ml/min, with maximum online operating pressure being 2.5bar (36 psi).

An optional inlet reduction valve is also available for high pressure applications.

## Complies with the latest industry standards

The IOS is designed in accordance with the latest global standards including:

- CE marking
- EC Declaration of Conformity
- Machinery Directive
- EMC EN61000-6-3:2001
- EMC EN61000-6-2:2001
- EN 61010-1:2001

## Pressure reducing valve (PRV)

A pressure compensated PRV device (Parker Hannifin part number ACC6NN027) has been developed to enable testing where flow pressures in the hose exceeds 2.5 bar, up to a maximum of 350 bar.

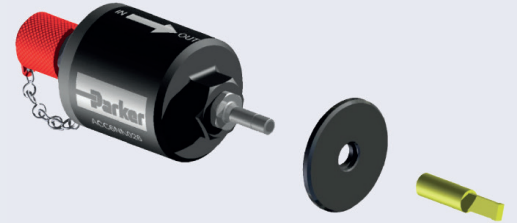

Parameter	Value
Working pressure range	0 to 2.5 bar
Working pressure with PRV	2.5 to 350 bar
Working viscosity	1 to 300 centistokes



## High Pressure Connection

Manual Connection: Press the Pressure Reducing Valve firmly into the INLET port



## Low Pressure Connection

Connect INLET (6mm Dia.) hose



Results are viewed in the OLED digital display window

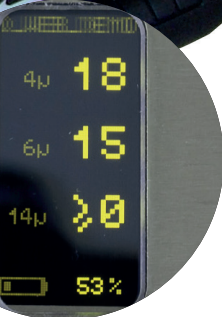

# Engineered for simplicity

## Parker quality and reliability as standard.

The IOS quality condition monitor for hydraulic oils uses advanced technology to produce extremely repeatable results.

At the heart of the system is a sophisticated laser and detector, using a light obscuration flow cell, providing continuous measurement of fluid flow passing through a sample tube.

Measurements are taken every second as standard, although measurement intervals and test period can be defined by the user, with results being reported immediately and updated in real time.

Data is displayed on a built-in OLED digital display and can also be stored for subsequent upload via the embedded icount's web page interface connecting through an RJ45 cable.

## Proven laser detection technology

Parker's experience in laser light obscuration and the application of that technology in portable particle counting is what places the icountOS ahead in the market.



## Hydraulic circuit

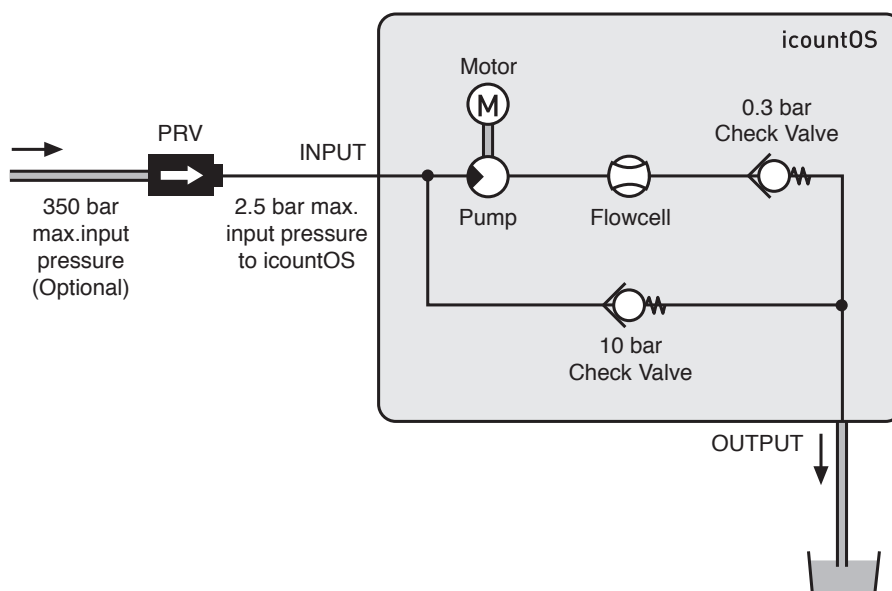



# How the icountOS works

Fig 1.

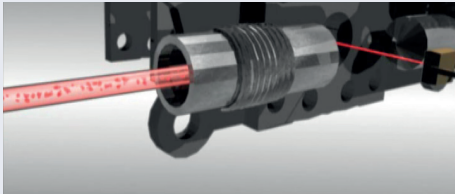

In simple terms, a controlled column of contaminated fluid enters the laser optical scanner chamber. This design maintains contamination distribution within the fluid.

Fig 2.

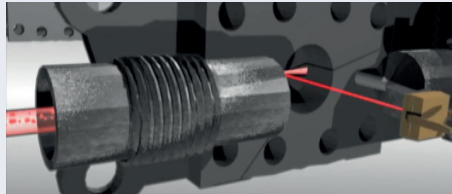

On reaching the IOS's photo diode cell, the accurate laser light is applied and projected through that oil column. The laser diode projects an image of the sample onto a photo diode cell.

Fig 3.



A cast image or shadow created by the contaminant in the oil creates a measurable change in the light intensity.

## Low Pressure connection set up

We recommend that the IOS is positioned in a safe, stable area, as close as possible to the system output and only the hose fittings provided are used.

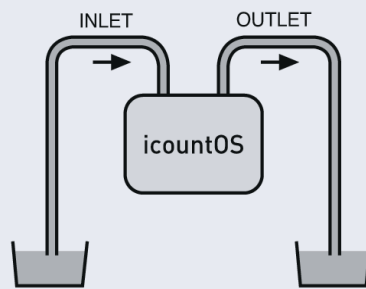

Option 1

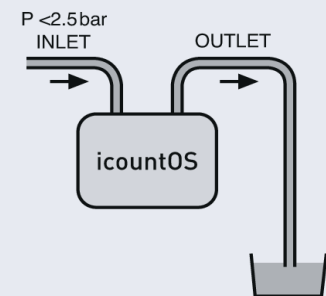

Option 2

## High Pressure connection set up (Optional equipment needed)

(High pressure defined for the IOS as more than 2.5 bar, with max. 350 bar).

We recommend that the IOS is positioned in a safe, stable area, as close as possible to the system output and only the provided hose fittings are used. For pressure systems (more than 2.5 bar) one high pressure hose assembly:

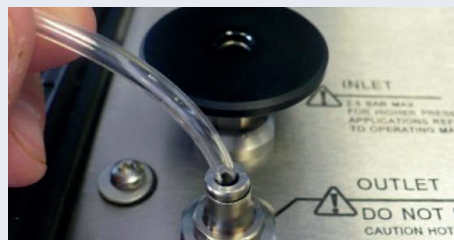
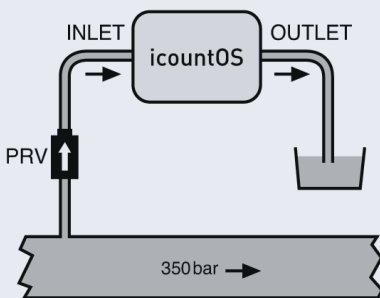

Attach OUTLET (4mm Dia.) hose



To remove the PRV, press down on the removal tool at the same time as lifting PRV off.

# The icountOS Web Interface with its own web page generator.

A Parker utility that comes as standard with IOS.

Uniquely, the IOS has its own web page generator which means that stored data can be downloaded or viewed on any PC or laptop.

Utilising a computer's web browser utility, or for non-wifi plug in the network cable, open the browser and enter the IOS's unique IP /MAC address in the navigation bar.



## Connecting the WiFi

1. Ensure your IOS is powered up and fully charged
2. Switch the IOS on by pressing the power button and allow it to go through the screen boot-up sequence
3. Press the wireless switch to ON
4. Obtain the IP address from the top of the IOS's display. When using a smart phone or tablet, go to the wireless network connection setting and ensure that the connection with the IOS product serial number (wireless router) is selected from the list
5. Launch your web browser and enter the product IP address and press GO
6. The icountOS web page should be displayed





# Configuration

## Data log page



### KEY

1. Start and Stop data logging
2. Save data in one of three data formats
  - TXT Format
  - CSV (Comma Separated Variables)
  - XML
3. Clear data logging memory
4. List of the five last samples taken
5. Memory usage

## Configuration page

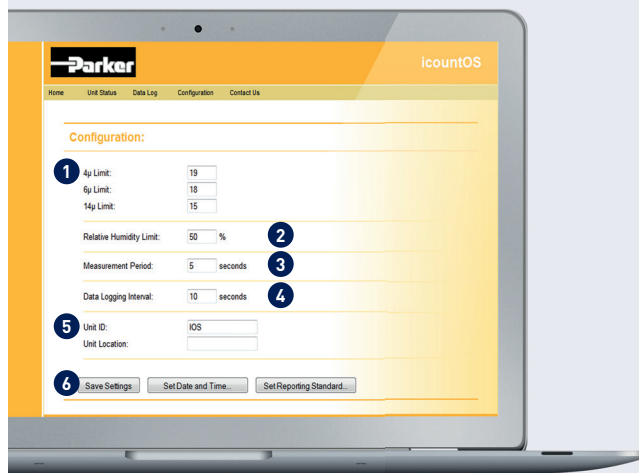

### KEY

1. Alarm limit settings for:
  - 4µm channel (c)
  - 6µm channel (c)
  - 14µm channel (c)
2. Alarm limit setting for relative humidity
3. Measurement period
4. Data logging interval
5. Unit name
6. Unit location

## Configuration: set report standard page

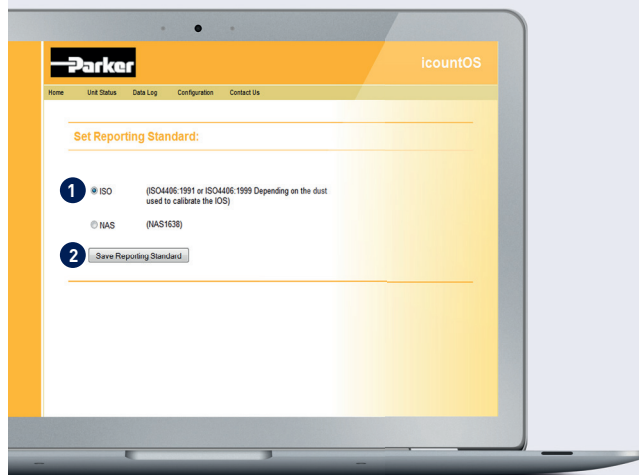

### KEY

1. Select either the ISO4406:1991 or ISO4406:1999 standard
2. Confirm the selected standard

# Technical specifications

## What is included?

### Offline IOS 1210 EUR/UK/US

- 1 x IOS Oil Sampler Unit
- + 1 x Power Supply
- + 1 x RJ45 LAN Cable
- + Low Pressure Hoses

### Online IOS 1220 EUR/UK/US

- 1 x IOS Oil Sampler Unit
- + 1 x Power Supply
- + 1 x RJ45 LAN Cable
- + 1 x Low Pressure Hose
- + 1 x Pressure Release Valve
- + 1 x High Pressure Hose

## Dimensions

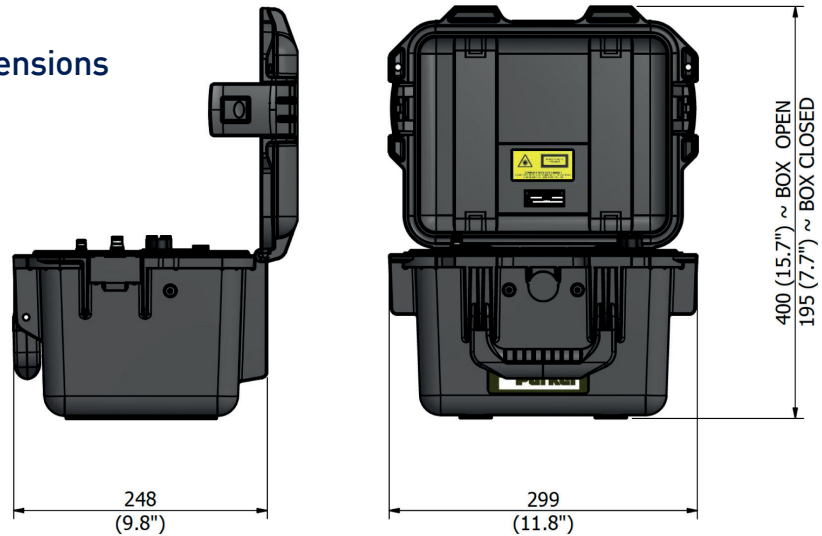

Feature	Specification
Product start-up time	10 seconds minimum
Measurement period	Default 30 seconds run time; 15 seconds data logging time
Reporting interval	On board data storage every second. Output via RJ45 connection
Principle of operation	Laser diode optical detection of actual particulates
International codes range	Up to ISO 22 (+/- 1 ISO code) NAS 0-12
Calibration	Calibration by recognised online methods confirmed by the relevant ISO procedures. MTD - via a certified primary ISO 11171 automatic particle detector using ISO 11943 principles. Particle distribution reporting to ISO 4406:1999.
Recalibration and Servicing	Recommended every 12 months
Working pressure	2.5-350 bar (35-5000psi) Pressures above 2.5 bar require the use of a Parker Pressure Reducing Valve (PRV) - ACC6NN027
Working viscosity	1-300 cSt
Flow range through IOS	40-140ml/minute; controlled at 60ml/min by IOS's internal pump
Fluid connection interface	INLET: 6mm push-fit. DRAIN: 4mm push-fit
Ambient storage temperature for unit	-40°C to +80°C; -40°F to +176°F
Operating temperature for unit	-30°C to +80°C; -22°F to +176°F
Operating humidity range	5%RH to 100%RH
Fluid operating temperature (Oil)	+5°C to +80°C ; +41 °F to +176°F
Moisture sensor	Linear scale within the range 5%RH to 100%RH
Computer compatibility	IP68-rated RJ45 connection that may be connected to a laptop computer's RJ45 LAN port using the 2m cable supplied, WiFi capability 20 metres indoors.
Power requirement	Regulated power supply supplied with the unit
Certification	IP54 rating (unit open) EMC EN61000-6-3:2001 IP67 rating (unit closed) EMC EN61000-6-2:2001 EC Declaration of Conformity EMC EN61010-1:2001 Machinery Directive CE Certified



# icountOS ordering information

## Ordering Information

Part Number	Fluid Type	Calibration	Connection	Option
IOS1210EUR	Mineral	MTD	Offline	None
IOS1220EUR	Mineral	MTD	On line	None
IOS1211EUR	Mineral	MTD	Offline	WiFi
IOS1221EUR	Mineral	MTD	On line	WiFi

## Accessory Part Numbers

Description	Part number
Hose Kit Bag (includes one power pack, RJ45 patch cable and low pressure hose connectors)	ACC6NN029UK ACC6NN029EUR ACC6N N029US
Pressure Reducing Valve (PRV)	ACC6NN027 (Standard with IOS 1220)
Power Pack (UK 2m cable)	ACC6NN040
Power Pack (EUR 2m cable)	ACC6NN041
Power Pack (US 2m cable)	ACC6NN042

Description	Part number
RJ45 LAN Connector Cable	ACC6NN028
Carry Strap	ACC6NN030  The Carry Strap option MUST be selected at the time of placing the IOS order.
Low Pressure Hoses (4mm and 6mm)	ACC6NN031
High Pressure Hose Assembly	ACC6NN034 (Standard with IOS 1220)
Verification Fluid	SER.MISC.067

## Important Information

**WARNING – USER –RESPONSIBILITY** - FAILURE OR IMPROPER SELECTION OR IMPROPER USE OF THE PRODUCTS DESCRIBED HEREIN OR RELATED ITEMS CAN CAUSE DEATH, PERSONAL INJURY AND PROPERTY DAMAGE.

- This document and other information from Parker-Hannifin Corporation, its subsidiaries and authorized distributors provide product or system options for further investigation by users having technical expertise.
- The user, through their own analysis and testing, is solely responsible for making the final selection of the system and components and assuring that all performance, endurance, maintenance, safety and warning requirements of the applications are met.
- The user must analyse all aspects of the application, follow applicable industry standards, and follow the information concerning the product in the current product catalogue and in any other materials provided from Parker or its subsidiaries or authorised distributors.
- To the extent that Parker or its subsidiaries or authorized distributors provide component or system options based upon data or specifications provided by the user, the user is responsible for determining that such data and specifications are suitable and sufficient for all applications and reasonably foreseeable uses of the components or systems. The operation of the products described here in is subject to the operating and safety procedures details of which are available upon request.

## Sales conditions

The items described in this document are available for sale by Parker Hannifin Corporation, its subsidiaries or its authorized distributors. Any sale contract entered into by Parker will be governed by the provisions stated in Parker's standard terms and conditions of sale (copy available upon request)

# Total system health management - Parker Condition Monitoring

**icountBSplus - Particle Counter**  
Offline + Online  
Bottle Sampler



### Product Features

- Quick sample bottle analysis with variable test time options from 15 seconds and volume capacities from 25ml.
- Repeatable and re-producible result performance to ISO4406:1999, NAS1638 AS4509E and GOST 17216:2001 (Differential and Cumulative) particle count distributions.
- On-board compressor and 'shop' air capability.
- CE compliant.

### Specifications

- Principle of operation is Laser diode optical detection of actual particulates.
- Fluid compatibility - Mineral-based oils and petroleum-based fuel.
- Viscosity range of the icountBSplus is 1 to 300cSt.
- Online sampling feature for pressures up to 350 bar.

### Ordering Information

Key	Version		Options		Region	Part Number
IBS	Plus	3	Online	000	Global	IBS3000
IBS	Plus	3	Offline	100	Global	IBS3100

**FPS**  
Fluid Property  
Sensor



### Product Features

- Simultaneous measurement of viscosity, density, dielectric constant & temperature
- Field or laboratory use
- Data logging
- Programmable sample rates
- Compact rugged construction
- Operates using Harmonics (tuning fork) Technology

### Specifications

- Up to 50 cSt viscosity reporting
- Refresh rate - 30 seconds
- 12 Volt operating power supply
- IP68 compatible
- Max. operating pressure - 25 bar (max. 10% of operating time)

### Ordering Information

Part Number	Fluid Type	Communication	Cable connector kit
FPS2000	Mineral/Fuel	CAN-bus	4 pin plu connector

**icountPD**  
Online  
particle detector



### Product Features

- Independent monitoring of system contamination trends
- Continuous performance for prolonged analysis
- Visual indicators with power and alarm output warnings
- Self diagnostic software
- Cost effective solution to prolong fluid life and reduce machine downtime

### Specifications

- Full PC/PLC integration technology such as:- RS232 and 0-5 Volt, 4-20 mA, CAN(J1939)
- Set up and Data logging support software included
- Moisture % RH indicator (included)

### Ordering Information

Part Number	Fluis Type	Communication	Cable connector kit
IPD12322230	Mineral	RS232/4-20mA	M12, 8 pin plug connector
IPD12323230	Mineral	RS232/0-5V	M12, 8 pin plug connector
IPD22322230	Aggressive	RS232/0-520V	M12, 8 pin plug connector

**icountPDR**  
Robust online  
particle detector



### Product Features

- Independent monitoring of system contamination trends
- Rugged design ensures protection against environmental exposure
- Small and compact device constructed in stainless steel
- Continuous performance for prolonged analysis
- Cost effective solution to prolong fluid life and reduce machine downtime

### Specifications

- Full PC/PLC integration technology such as:- RS232 and 0-5 Volt, 4-20 mA, CAN(J1939)
- Set up and Data logging support software included
- Moisture % RH indicator

### Ordering Information

Part Number	Communication	Cable connector kit
IPDR12115240	RS232/CAN-bus	M12, 12 pin plug connector
IPDR12112240	RS232/4-20mA	M12, 12 pin plug connector
IPDR12113240	RS232/0-5V	M12, 8 pin plug connector



**MHC-Bearing  
Checker**  
Acoustic Emissions  
Instrument



**Product Features**

- Simple Acoustic Emission measurement tool to assess bearing condition.
- Simple handheld device for determining the condition of rotating bearings and inadequate lubrication.
- The unit can instantly detect if there is a problem, allowing corrective action to be taken to prevent further damage or machine failure.

**Specifications**

- Operating temperature: 0°C to 65°C
- Dimensions: 98 mm x 62 mm x 34 mm (including magnetic sensor)
- Weight: 225g

**Ordering Information**

Part Number	Product Description
FGH11510PA	MHC Bearing Checker

**Heated  
Viscometer**  
Viscosity  
Measurements



**Product Features**

- Accurate viscosity measurement in the field
- Rolling ball technique for high accuracy
- Direct readings in cSt @ 40
- Laboratory grade oil viscosity results in minutes

**Specifications**

- Range: Calculated viscosity @ 40°C, 50°C and 100°C
- Display: 8 digit LED
- Power: 100/240 Volts. User specified

**Ordering Information**

Part Number	Product Description
FGK1200PA	Heated Viscometer, power supply and all consumables in portable metal case

**ANALEXfdMplus**  
Ferrous Debris  
Monitor



**Product Features**

- Lab grade test for ferrous debris wear in the field
- Provides direct PPM measurement
- Measures both oils and greases
- Features adaptors for many bottles / syringes / pots

**Specifications**

- Power: 100 – 250 VAC auto selected 50/60 Hz
- Operating temperature range: 15 - 40°C
- Weight: 4.22 kg

**Ordering Information**

Part Number	Product Description
FGK17144PA	ANALEXfdMplus
FGK14946PA	x 360 off 50ml Sample Bottles
FGK15005PA	x 3000 off Grease Pots
FGK17074PA	x 1000 off 5ml Test Tubes
FGK17075PA	x 500 off 10ml Syringes
FGK17076PA	x 500 off 15ml Syringes

**Low Range  
DIGI Water Kit**  
Accurate results  
for water in oil



**Product Features**

- Electronic display gives simple, step by step instructions
- Fully portable for use on-board or in the field
- Fast, accurate results
- State of the art digital analysis

**Specifications**

- Range: 0.02 – 1%, 100 – 3000 ppm, 0 – 10%
- Test time: 3 minutes
- Battery Life: Five years

**Ordering Information**

Part Number	Product Description
FGK17032PA	Low
FGK2101PA	Easy

# Parker Worldwide

## Europe, Middle East, Africa

**AE – United Arab Emirates,** Dubai  
Tel: +971 4 8127100  
parker.me@parker.com

**AT – Austria,** Wiener Neustadt  
Tel: +43 (0)2622 23501-0  
parker.austria@parker.com

**AT – Eastern Europe,** Wiener Neustadt  
Tel: +43 (0)2622 23501 900  
parker.easteurope@parker.com

**AZ – Azerbaijan,** Baku  
Tel: +994 50 2233 458  
parker.azerbaijan@parker.com

**BE/LU – Belgium,** Nivelles  
Tel: +32 (0)67 280 900  
parker.belgium@parker.com

**BG – Bulgaria,** Sofia  
Tel: +359 2 980 1344  
parker.bulgaria@parker.com

**BY – Belarus,** Minsk  
Tel: +375 17 209 9399  
parker.belarus@parker.com

**CH – Switzerland,** Etoy  
Tel: +41 (0)21 821 87 00  
parker.switzerland@parker.com

**CZ – Czech Republic,** Klecany  
Tel: +420 284 083 111  
parker.czechrepublic@parker.com

**DE – Germany,** Kaarst  
Tel: +49 (0)2131 4016 0  
parker.germany@parker.com

**DK – Denmark,** Ballerup  
Tel: +45 43 56 04 00  
parker.denmark@parker.com

**ES – Spain,** Madrid  
Tel: +34 902 330 001  
parker.spain@parker.com

**FI – Finland,** Vantaa  
Tel: +358 (0)20 753 2500  
parker.finland@parker.com

**FR – France,** Contamine s/Arve  
Tel: +33 (0)4 50 25 80 25  
parker.france@parker.com

**GR – Greece,** Athens  
Tel: +30 210 933 6450  
parker.greece@parker.com

**HU – Hungary,** Budaörs  
Tel: +36 23 885 470  
parker.hungary@parker.com

**IE – Ireland,** Dublin  
Tel: +353 (0)1 466 6370  
parker.ireland@parker.com

**IT – Italy,** Corsico (MI)  
Tel: +39 02 45 19 21  
parker.italy@parker.com

**KZ – Kazakhstan,** Almaty  
Tel: +7 7273 561 000  
parker.easteurope@parker.com

**NL – The Netherlands,** Oldenzaal  
Tel: +31 (0)541 585 000  
parker.nl@parker.com

**NO – Norway,** Asker  
Tel: +47 66 75 34 00  
parker.norway@parker.com

**PL – Poland,** Warsaw  
Tel: +48 (0)22 573 24 00  
parker.poland@parker.com

**PT – Portugal,** Leca da Palmeira  
Tel: +351 22 999 7360  
parker.portugal@parker.com

**RO – Romania,** Bucharest  
Tel: +40 21 252 1382  
parker.romania@parker.com

**RU – Russia,** Moscow  
Tel: +7 495 645-2156  
parker.russia@parker.com

**SE – Sweden,** Spånga  
Tel: +46 (0)8 59 79 50 00  
parker.sweden@parker.com

**SK – Slovakia,** Banská Bystrica  
Tel: +421 484 162 252  
parker.slovakia@parker.com

**SL – Slovenia,** Novo Mesto  
Tel: +386 7 337 6650  
parker.slovenia@parker.com

**TR – Turkey,** Istanbul  
Tel: +90 216 4997081  
parker.turkey@parker.com

**UA – Ukraine,** Kiev  
Tel: +380 44 494 2731  
parker.ukraine@parker.com

**UK – United Kingdom,** Warwick  
Tel: +44 (0)1926 317 878  
parker.uk@parker.com

**ZA – South Africa,** Kempton Park  
Tel: +27 (0)11 961 0700  
parker.southafrica@parker.com

## North America

**CA – Canada,** Milton, Ontario  
Tel: +1 905 693 3000

**US – USA,** Cleveland  
Tel: +1 216 896 3000

## Asia Pacific

**AU – Australia,** Castle Hill  
Tel: +61 (0)2-9634 7777

**CN – China,** Shanghai  
Tel: +86 21 2899 5000

**HK – Hong Kong**  
Tel: +852 2428 8008

**IN – India,** Mumbai  
Tel: +91 22 6513 7081-85

**JP – Japan,** Tokyo  
Tel: +81 (0)3 6408 3901

**KR – South Korea,** Seoul  
Tel: +82 2 559 0400

**MY – Malaysia,** Shah Alam  
Tel: +60 3 7849 0800

**NZ – New Zealand,** Mt Wellington  
Tel: +64 9 574 1744

**SG – Singapore**  
Tel: +65 6887 6300

**TH – Thailand,** Bangkok  
Tel: +662 186 7000

**TW – Taiwan,** Taipei  
Tel: +886 2 2298 8987

## South America

**AR – Argentina,** Buenos Aires  
Tel: +54 3327 44 4129

**BR – Brazil,** Sao Jose dos Campos  
Tel: +55 800 727 5374

**CL – Chile,** Santiago  
Tel: +56 2 623 1216

**MX – Mexico,** Toluca  
Tel: +52 72 2275 4200

European Product Information Centre  
Free phone: 00 800 27 27 5374  
(from AT, BE, CH, CZ, DE, DK, EE, ES, FI,  
FR, IE, IL, IS, IT, LU, MT, NL, NO, PL, PT, RU,  
SE, SK, UK, ZA)

© 2014 Parker Hannifin Corporation. All rights reserved.

Catalogue FDCB615UK 11/2014 FC



**Parker Hannifin Ltd.**  
Hydraulic Filter Division Europe  
commoninfo@parker.com  
kittiwakesales@parker.com  
www.parker.com/hfde  
www.kittiwake.com

Your local authorized Parker distributor